

# MFH 200 and MFH 300 MICROMASTER

CURTAIN WALL D01 and D02 FRONT MOUNT

GLASS DOOR TO GLASS FRAME

DOOR	FRAME	WASHER	SPACER	"A"	"B"
10mm	10 mm	0.8 mm	N/A	38	60
10mm	12 mm	0.8 mm	N/A	38	60
10mm	15mm	0.8 mm	N/A	40	60
10mm	19mm	0.8 mm	N/A	42	60
12mm	10mm	0.8 mm	N/A	38	60
12mm	12mm	0.8 mm	N/A	38	60
12mm	15mm	0.8 mm	N/A	40	60
12mm	19mm	0.8 mm	N/A	42	60
15mm	10mm	0.8 mm	2mm	40	60
15mm	12mm	0.8 mm	2mm	40	60
15mm	15mm	0.8 mm	N/A	40	60
15mm	19mm	0.8 mm	N/A	42	60
19mm	10mm	0.8 mm	10mm	48	60
19mm	12mm	0.8 mm	10mm	48	60
19mm	15 mm	0.8 mm	8mm	48	60
19mm	19 mm	0.8 mm	6mm	48	60

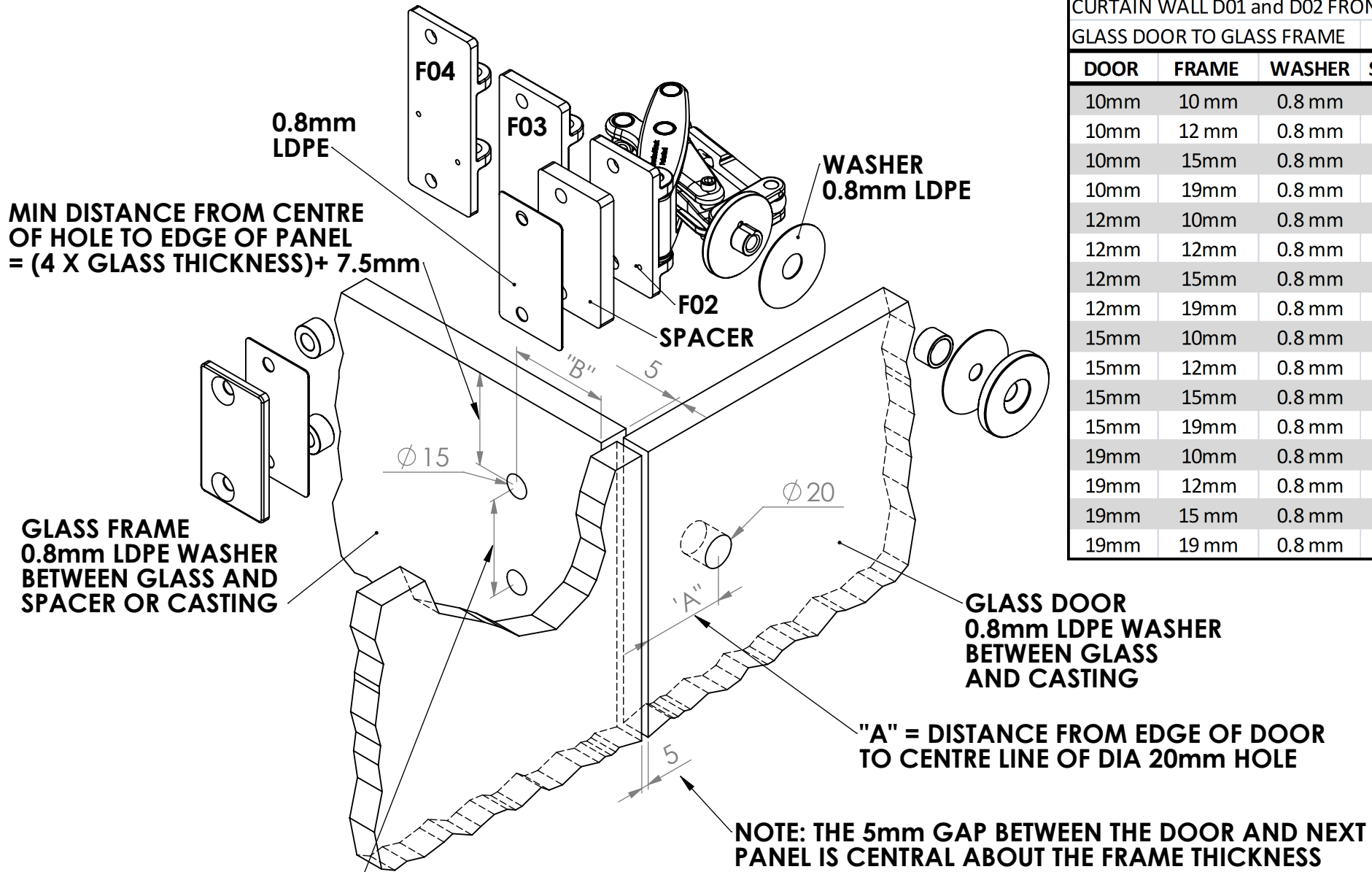

MIN DISTANCE FROM CENTRE OF HOLE TO EDGE OF PANEL = (4 X GLASS THICKNESS)+ 7.5mm

GLASS FRAME  
0.8mm LDPE WASHER  
BETWEEN GLASS AND  
SPACER OR CASTING

GLASS DOOR  
0.8mm LDPE WASHER  
BETWEEN GLASS  
AND CASTING

"A" = DISTANCE FROM EDGE OF DOOR  
TO CENTRE LINE OF DIA 20mm HOLE

NOTE: THE 5mm GAP BETWEEN THE DOOR AND NEXT  
PANEL IS CENTRAL ABOUT THE FRAME THICKNESS

F02 = 64mm (10 and 12mm)  
F03 = 80mm (10, 12 and 15mm)  
F04 = 96mm (10, 12, 15 and 19mm)

