

MFH 200 and MFH 300 MICROMASTER

CURTAIN WALL D01 and D02 FRONT MOUNT CSK
GLASS DOOR TO NON GLASS FRAME

| DOOR | FRAME | WASHER | SPACER | "A" | "B" |
|------|-------|--------|--------|-----|-----|
| 10mm | 10 mm | 5.5 mm | N/A | 37 | 64 |
| 10mm | 12 mm | 5.5 mm | N/A | 37 | 64 |
| 10mm | 16mm | 5.5 mm | N/A | 40 | 64 |
| 10mm | 20mm | 5.5 mm | N/A | 42 | 64 |
| 12mm | 10mm | 3.5 mm | N/A | 37 | 62 |
| 12mm | 12mm | 3.5 mm | N/A | 37 | 62 |
| 12mm | 16mm | 3.5 mm | N/A | 40 | 62 |
| 12mm | 20mm | 3.5 mm | N/A | 42 | 62 |
| 15mm | 10mm | 0.8 mm | 4mm | 40 | 60 |
| 15mm | 12mm | 0.8 mm | 2mm | 40 | 60 |
| 15mm | 16mm | 0.8 mm | N/A | 40 | 60 |
| 15mm | 20mm | 0.8 mm | N/A | 42 | 60 |
| 19mm | 10mm | 0.8 mm | 10mm | 47 | 60 |
| 19mm | 12mm | 0.8 mm | 10mm | 48 | 60 |
| 19mm | 16 mm | 0.8 mm | 8mm | 48 | 60 |
| 19mm | 20 mm | 0.8 mm | 6mm | 48 | 60 |

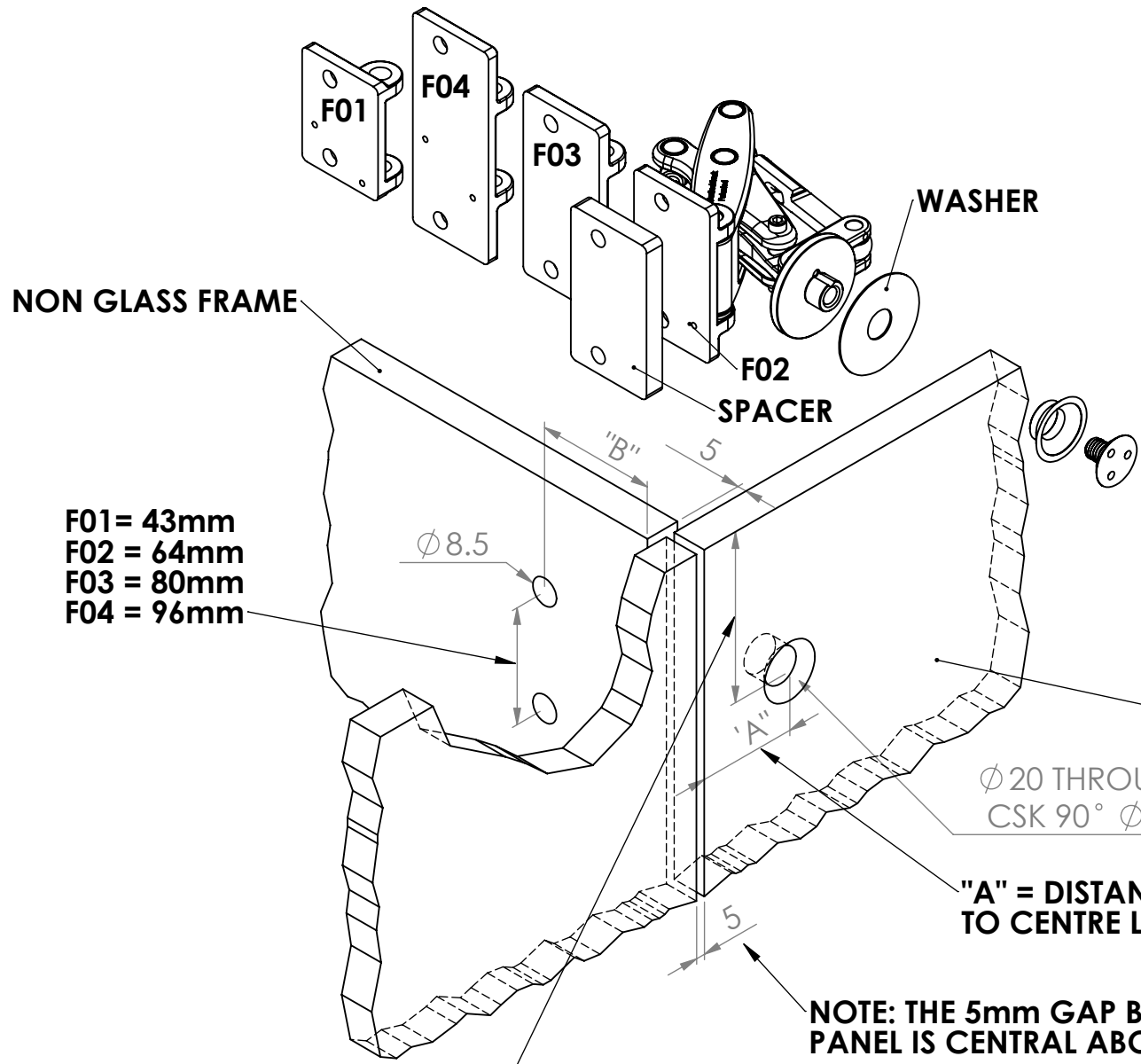

F01 = 43mm
F02 = 64mm
F03 = 80mm
F04 = 96mm

GLASS DOOR
0.8mm LDPE WASHER
OR ACETAL WASHER
BETWEEN GLASS
AND CASTING

"A" = DISTANCE FROM EDGE OF DOOR
TO CENTRE LINE OF DIA 20mm HOLE

**NOTE: THE 5mm GAP BETWEEN THE DOOR AND NEXT
PANEL IS CENTRAL ABOUT THE FRAME THICKNESS**

**MIN DISTANCE FROM CENTRE
OF HOLE TO EDGE OF PANEL
= (4 X GLASS THICKNESS)+10mm**

