

# MFH 200 and MFH 300 MICROMASTER

CURTAIN WALL D01 and D02 FRONT MOUNT  
GLASS DOOR TO NON GLASS FRAME

DOOR	FRAME	WASHER	SPACER	"A"	"B"
10mm	10 mm	0.8 mm	N/A	37	60
10mm	12 mm	0.8 mm	N/A	37	60
10mm	16mm	0.8 mm	N/A	40	60
10mm	20mm	0.8 mm	N/A	42	60
12mm	10mm	0.8 mm	N/A	37	60
12mm	12mm	0.8 mm	N/A	37	60
12mm	16mm	0.8 mm	N/A	40	60
12mm	20mm	0.8 mm	N/A	42	60
15mm	10mm	0.8 mm	4mm	40	60
15mm	12mm	0.8 mm	2mm	40	60
15mm	16mm	0.8 mm	N/A	40	60
15mm	20mm	0.8 mm	N/A	42	60
19mm	10mm	0.8 mm	10mm	47	60
19mm	12mm	0.8 mm	10mm	48	60
19mm	16 mm	0.8 mm	8mm	48	60
19mm	20 mm	0.8 mm	6mm	48	60

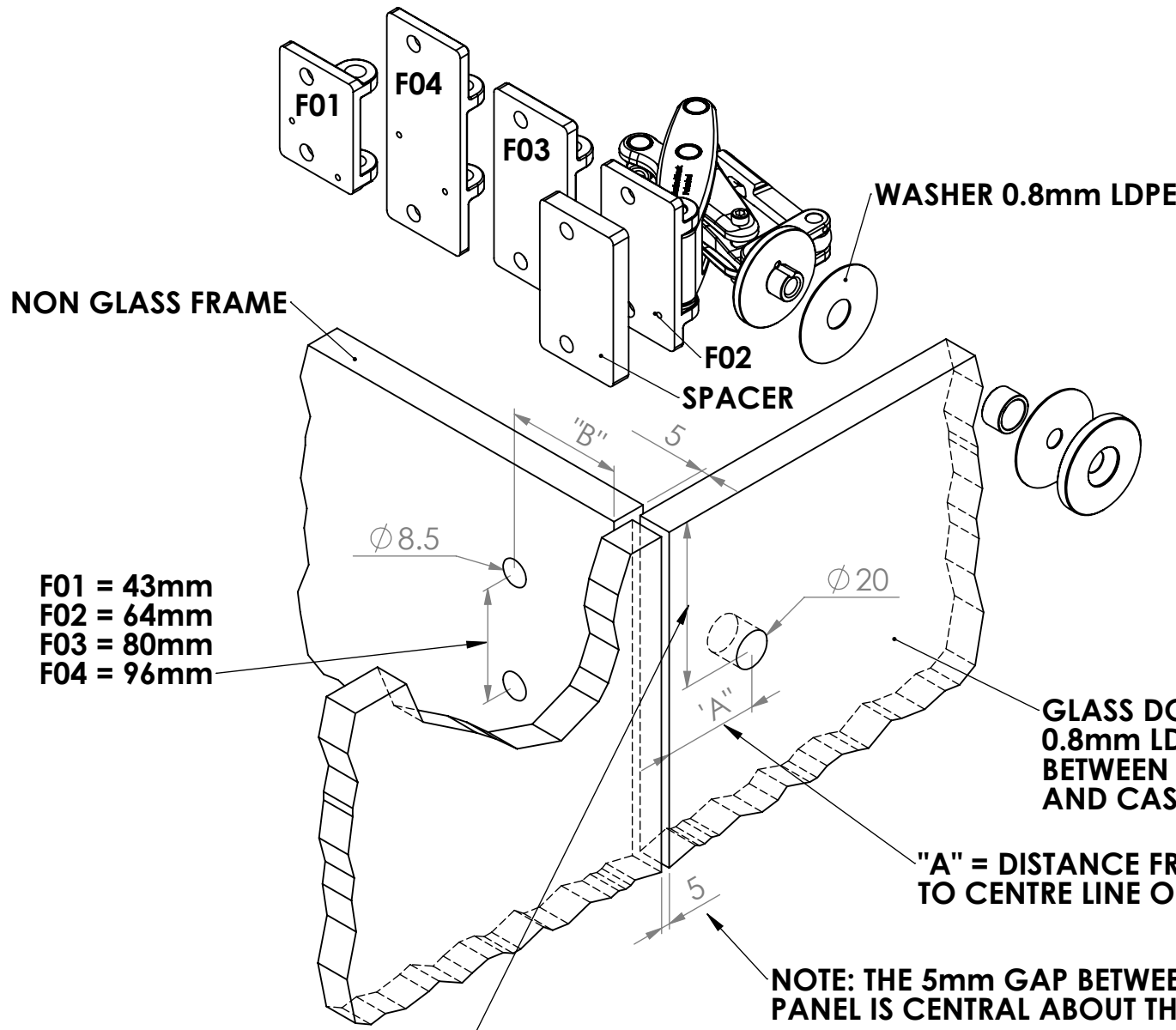

- F01 = 43mm
- F02 = 64mm
- F03 = 80mm
- F04 = 96mm

MIN DISTANCE FROM CENTRE OF HOLE TO EDGE OF PANEL = (4 X GLASS THICKNESS)+10mm

