

MFH 200 and MFH 300 MICROMASTER

INSET D01 and D02 FRONT MOUNT CSK

GLASS DOOR TO GLASS FRAME

DOOR THICKNESS	"A"	"B"	WASHER	SPACER
10mm	30	80	5.5mm	N/A
12mm	34	80	3.5mm	4mm
15mm	40	80	0.8mm	10mm
19mm	48	84	0.8mm	18mm

GLASS FRAME
0.8mm LDPE WASHER BETWEEN
GLASS AND SPACER OR CASTING

MIN DISTANCE FROM CENTRE
OF HOLE TO EDGE OF PANEL
= (4 X GLASS THICKNESS)+ 7.5mm

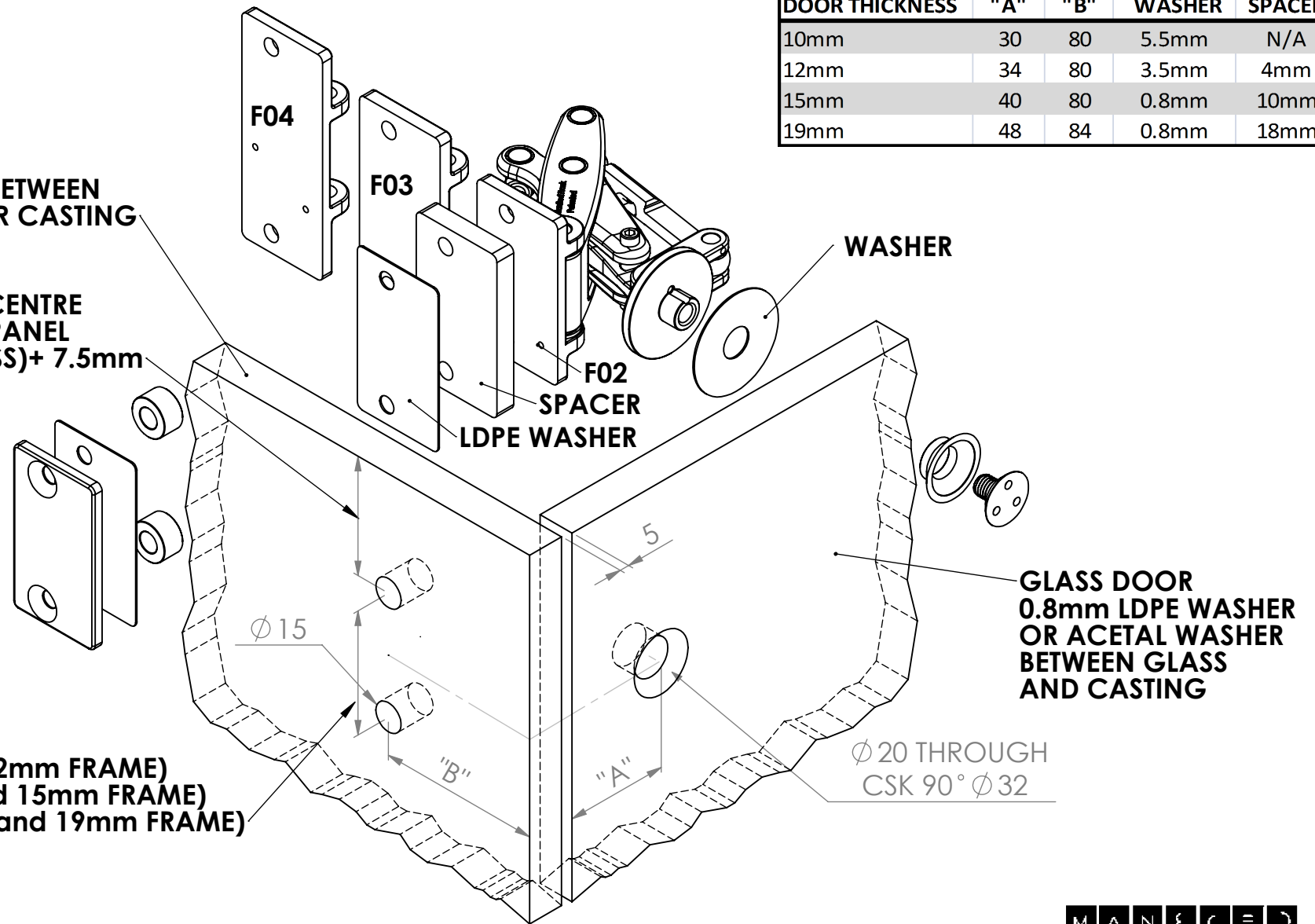

F02 = 64mm (10 and 12mm FRAME)
F03 = 80mm (10,12 and 15mm FRAME)
F04 = 96mm (10,12,15 and 19mm FRAME)

